

ICS 75.180.10; 77.140.75

ČSN
EN ISO 11961
Oprava 1

45 1392

Prosinec 2009

ČESKÁ TECHNICKÁ NORMA

Naftový a plynárenský průmysl – Ocelové vrtné potrubí



EUROPEAN STANDARD

EN ISO 11961:2008/AC

NORME EUROPÉENNE

May 2009

EUROPÄISCHE NORM

Mai 2009

Mai 2009

ICS 75.180.10; 77.140.75

English version
Version Française
Deutsche Fassung

Petroleum and natural gas industries - Steel drill pipe (ISO 11961:2008/Cor 1:2009)

Industries du pétrole et du gaz naturel -
Tiges de forage en acier (ISO
11961:2008/Cor 1:2009)

Erdöl- und Erdgasindustrie - Stahl-
Bohrrohre (ISO 11961:2008/Cor 1:2009)

This corrigendum becomes effective on 13 May 2009 for incorporation in the official German and English versions of the EN.

Ce corrigendum prendra effet le 13 mai 2009 pour incorporation dans les versions officielles allemande et anglaise de la EN.

Die Berichtigung tritt am 13.Mai 2009 zur Einarbeitung in die offizielle Deutsche und Englische Fassung der EN in Kraft.



EUROPEAN COMMITTEE FOR STANDARDIZATION
COMITÉ EUROPÉEN DE NORMALISATION
EUROPÄISCHES KOMITEE FÜR NORMUNG

Management Centre: Avenue Marnix 17, B-1000 Brussels

© 2009 CEN All rights of exploitation in any form and by any means reserved worldwide for CEN national Members.
Tous droits d'exploitation sous quelque forme et de quelque manière que ce soit réservés dans le monde entier aux membres nationaux du CEN.
Alle Rechte der Verwertung, gleich in welcher Form und in welchem Verfahren, sind weltweit den nationalen Mitgliedern von CEN vorbehalten.

EN ISO 11961:2008/AC:2009 (E)

Endorsement notice

The text of ISO 11961:2008/Cor.1:2009 has been approved by CEN as a European Corrigendum without any modification.



INTERNATIONAL STANDARD ISO 11961:2008

TECHNICAL CORRIGENDUM 1

Published 2009-03-01

INTERNATIONAL ORGANIZATION FOR STANDARDIZATION • МЕЖДУНАРОДНАЯ ОРГАНИЗАЦИЯ ПО СТАНДАРТИЗАЦИИ • ORGANISATION INTERNATIONALE DE NORMALISATION

Petroleum and natural gas industries — Steel drill pipe

TECHNICAL CORRIGENDUM 1

Industries du pétrole et du gaz naturel — Tiges de forage en acier

RECTIFICATIF TECHNIQUE 1

Technical Corrigendum 1 to ISO 11961:2008 was prepared by Technical Committee ISO/TC 67, *Materials, equipment and offshore structures for petroleum, petrochemical and natural gas industries*, Subcommittee SC 5, *Casing, tubing and drill pipe*.

Page 69

Replace Figure B.1 with the following figure, in which the line “L” in subfigure b) has been shortened such that it does not extend below the lower shoulder of the tool-joint pin and the arrows designating $\varnothing d_p$ and $\varnothing d_{te}$ have been modified.

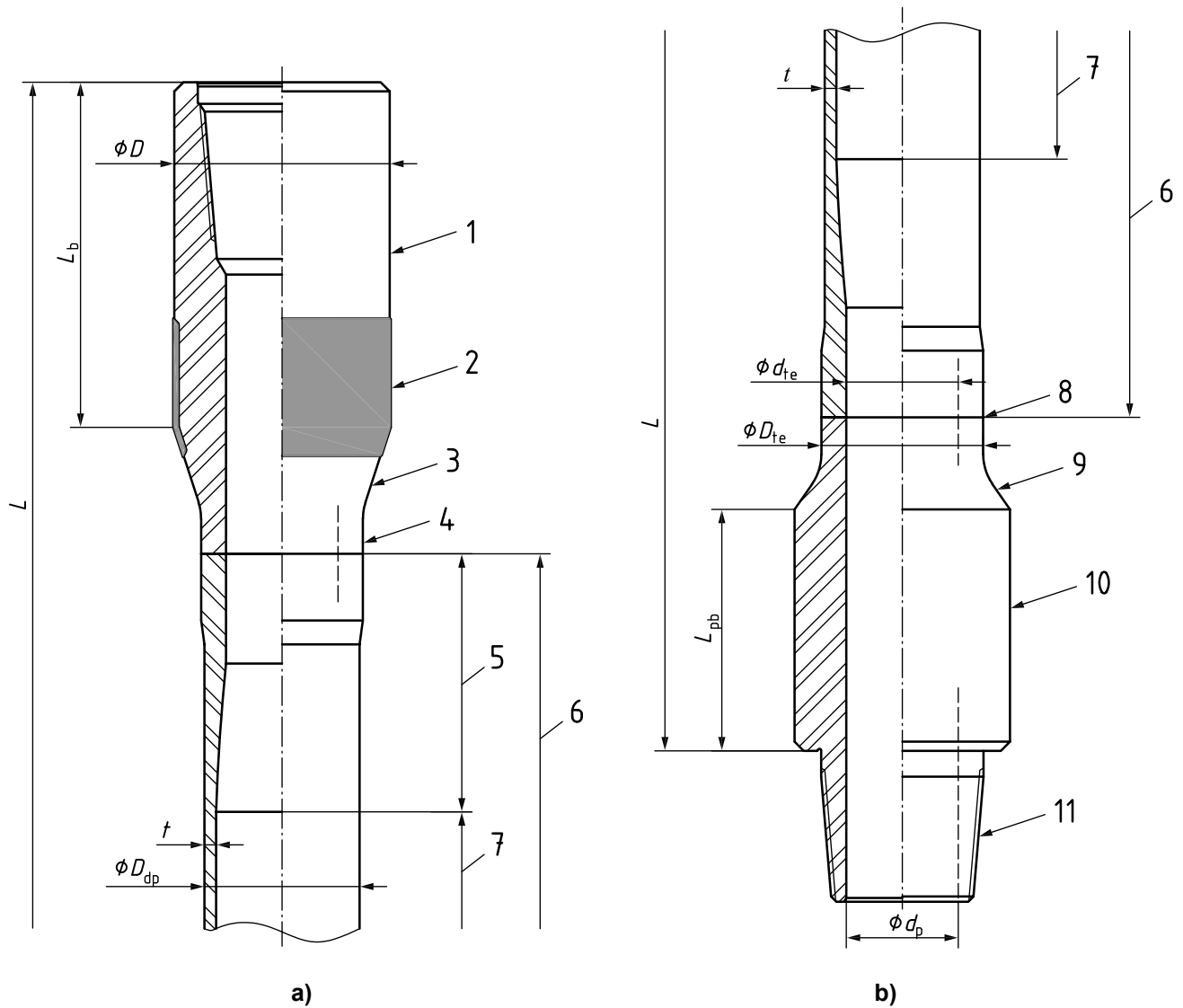

Key

- | | | | |
|---|---------------------------|----|------------------------------|
| 1 | tool-joint box | 7 | pipe body |
| 2 | hard banding (optional) | 8 | friction weld |
| 3 | tapered elevator shoulder | 9 | pin taper |
| 4 | drill-pipe weld neck | 10 | tool-joint pin |
| 5 | drill-pipe-body upset | 11 | rotary shouldered connection |
| 6 | drill-pipe-body | | |

NOTE See Tables A.1, A.2 or A.3 or Tables C.1, C.2 or C.3 and 6.2 for dimensional requirements.

Figure B.1 — Drill pipe

U p o z o r n ě n í : Změny a doplňky, jakož i zprávy o nově vydaných normách jsou uveřejňovány ve Věstníku Úřadu pro technickou normalizaci, metrologii a státní zkušebnictví.

ČSN EN ISO 11961 OPRAVA 1

Vydal Úřad pro technickou normalizaci, metrologii a státní zkušebnictví, Praha
Rok vydání 2009, 8 stran

83932 Cenová skupina 998



8 590963 839325